

Datasheet

DB_START_4CE10

Cyclone IV Development Board

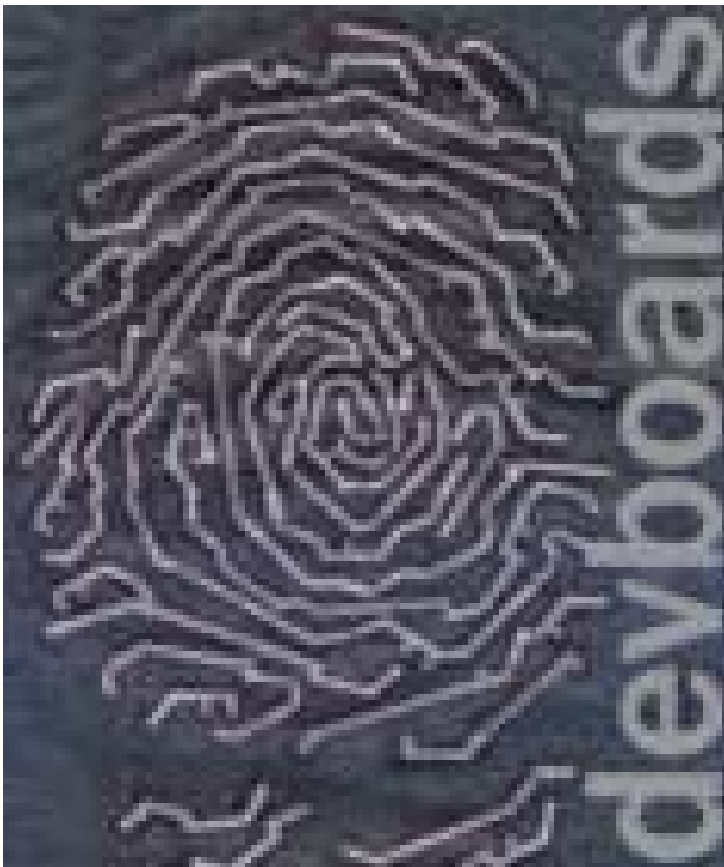

www.devboards.de

Contents

Contents	2
Revisions	3
Package contents	4
DB_START_4CE10	4
Introduction.....	5
Installation	6
Getting started	7
Documentation.....	7
Setting up the board.....	7
Flashing the board	7
Programming the configuration device	7
Reference designs.....	8
NIOS II Getting Started Tutorial	8
Signal Tap Tutorial.....	8
Board Description	9
FPGA Configuration.....	9
Clocking	9
Clock Distribution	9
SDRAM Clock Setting	9
Power Supply.....	9
Reset Signal	10
I/O Connections.....	11
SDRAM.....	11
FPGA Connection	12
Pin Header	14
I/O Connector P6.....	14
Buttons & LEDs.....	15
FPGA Connection	15
Bill of Material	16
Schematics	18
FPGA, Memory, IO	18
Power Supply.....	19
Embedded USB Blaster	20
Board Top View	21
Board Bottom View	22

DB_START_4CE10 – Cyclone IV Development Board

Revisions

Revision	Remark	Date
1.00	Initial Version	16.08.2010

Package contents

DB_START_4CE10

- DB_START_4CE10 Development Board
- Mini USB to USB Cable
- Reference Designs can be downloaded from www.devboards.de

DB_START_4CE10 – Cyclone IV Development Board

Introduction

The DB_START_4CE10 is a Cyclone IV Development Board with embedded USB-Blaster, Memory and IO Pins

The following features are integrated:

- EP4CE10E22C8N
- EPCS16 configuration device
- 16Mbyte SDRAM
- 19 I/O Pins
- 5x Input Pins
- 6x User LEDs
- 2x user buttons
- JTAG interface
- Crystal Oscillator
- Embedded USB Blaster on Board
- Power Supply via USB or external 5V Power supply
- on board 3.3V, 2.5V and 1.2V power supply
- dimension : 70x60mm²

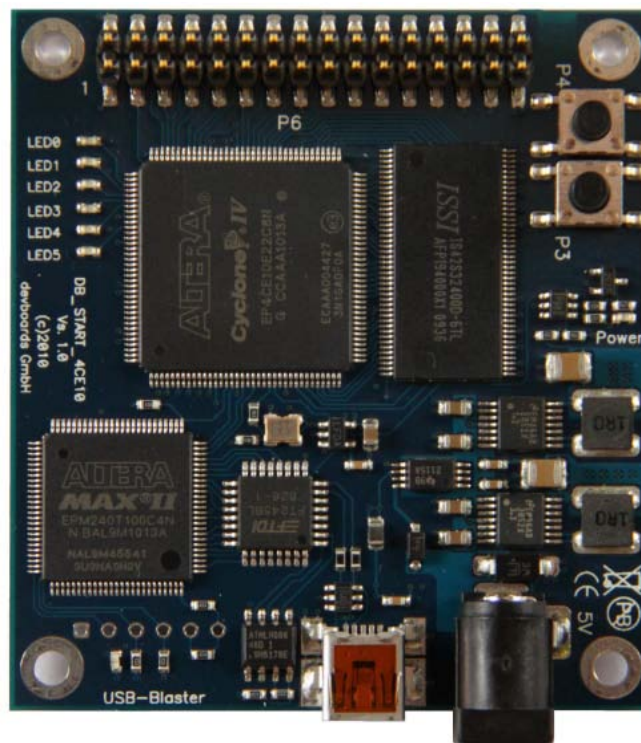

Figure 1

DB_START_4CE10 – Cyclone IV Development Board

Installation

Download and execute the DB_Start_4CE10_Setup.Exe file from www.devboards.de to install the Reference Designs and documentation. The Free Quartus Software and NIOS IDE can be downloaded from www.altera.com/download

Please install the applications in the following sequence:

- install the Quartus® 9.1SP2 Web Edition
- install Nios® II 9.1SP2 Version
- install the reference designs.

When you have finished the installation of the reference designs you can find the following folders on your hard disk:

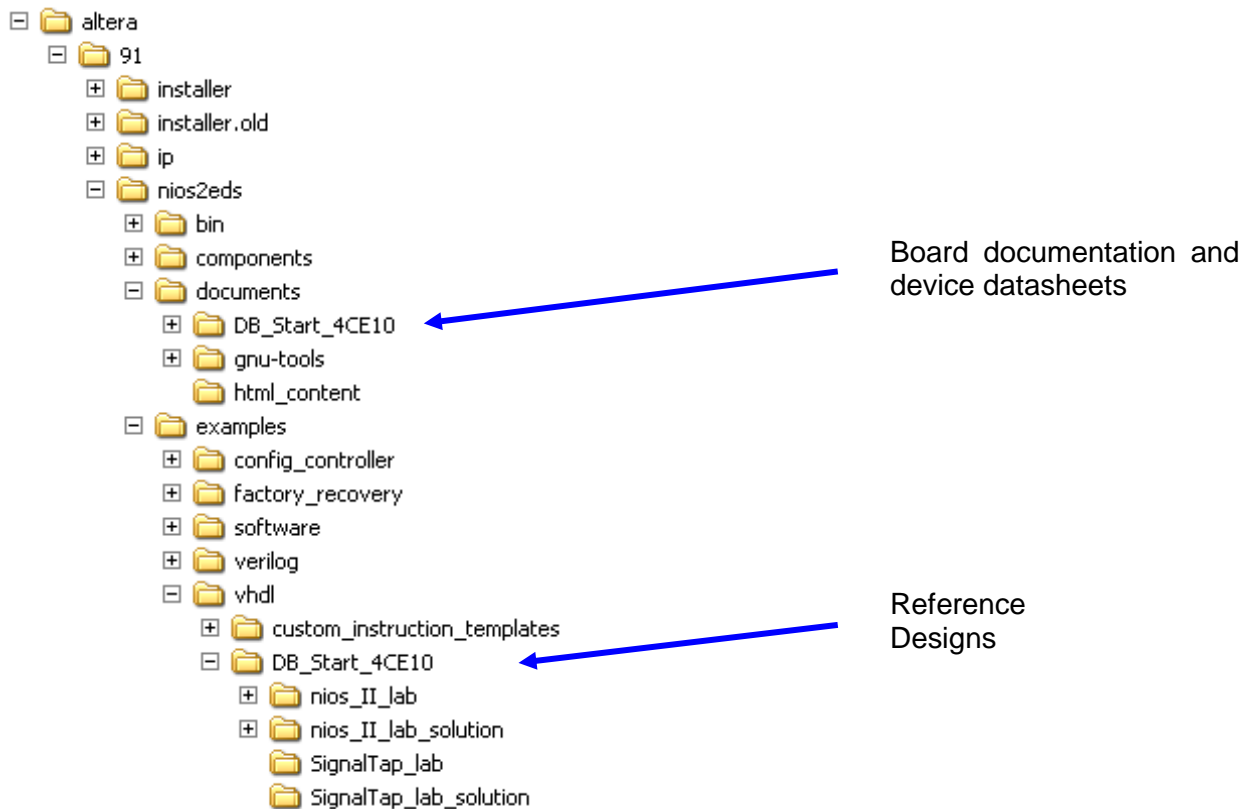

Getting started

Documentation

The complete documentation of the board, the reference designs, IP functions and the on-board devices are stored in the documentation directory of the Altera® Nios® II directory e.g. C:\Altera\91\nios2eds\documents\DB_START_4CE10.

Setting up the board

Connect the DB_Start_4CE10 Board via the USB Cable to the PC. The Power LED should lit and the board should be registered as an Altera USB-Blaster on your PC. After that you can work with the board.

IF you like to use the board with an external Power Supply, please make sure that the supply delivers 5V +/-10%. If you use an external Power supply, only the USB Blaster part of the Board will be supplied via USB, the rest is powered via the external power supply.

Flashing the board

Programming the configuration device

To program the EPCS16 configuration device on the DB_START_4CE10 Development Board, a JTAG indirect programming file (.jic) is used. In the file / convert programming file menu in Quartus® II a .SOF file can be converted into a .jic file. The .jic file can be selected in the Quartus® II programmer (in JTAG mode). Make sure that both configure / program lines are selected to download the loader into the FPGA and the SOF file into the configuration device.

The Nios® II IDE flash programmer can also be used to program a SOF file into the configuration device.

Reference designs

Documentation for the Reference Designs is located in the \Altera\91\nios2eds\examples\vhd\DB_Start_4CE10 folder.

NIOS II Getting Started Tutorial

As a NIOS II Starting point, a Step by Step Tutorial is available. This lab shows how to setup a NIOS II Processor, how to write C Code and debug it and how to add a custom peripheral to the NIOS II.

Signal Tap Tutorial

The Signal Tap Tutorial shows how to use the Signal Tap Logic Analyser inside the FPGA. Setup a small design, setup the SignalTap Logic Analyser and uses the In System Memory Content Editor to change parameters on the fly.

Board Description

FPGA Configuration

The DB_START_4CE10 Development Board includes an on-board USB Blaster that can be used to configure the FPGA, program the EPCS Configuration device, use the Signal-Tap Logic Analyser and together with the NIOS IDE to download and debug software.

Clocking

The DB_START_4CE10 Development Board includes a free running 24MHz Crystal Quartz Oscillator. The Crystal Quartz Oscillator drives the FPGA directly. Table 2 shows the clock distribution on the DB_START_4CE10 board. The Crystal Quartz Oscillator is a ± 50 ppm Clock source. One PLL is used to generate an external clock for the SDRAM.

Clock Distribution

Function	FPGA Pin	Signal Name
24MHz	23	Clk24
SDRAM Clock	127	SCLK

Table 1

SDRAM Clock Setting

The SDRAM Clock is generated from the FPGA PLL Output. The phase of the PLL should be set that

Offset delay of the PLL – tco of the Clock Signal is between -1.0 ns and -2.0 ns.

The Offset delay value can be found in the Quartus[®] II compilation report, Timing Analysis, Clock Setting Summary. The tco can be found in the tco-section.

Power Supply

The DB_START_4CE10 Development Board allows supplying the board either via the USB Connection to the PC or with a 5V regulated center-positive input power supply (P12). If both supplies are connected, the USB Supply is internally disconnected and the external 5V is used.

Figure 4 shows the Power distribution on the DB_Start_4CE10 board.

For details of the power supply refer to the schematic on the end of the document.

- 1.2V Core Voltage
- 2.5V Analog Supply for FPGA
- 3.3V I/O Voltage and supply for the other components

A Power Good signal is generated monitoring the 1.2V and 3.3V.

DB_START_4CE10 – Cyclone IV Development Board

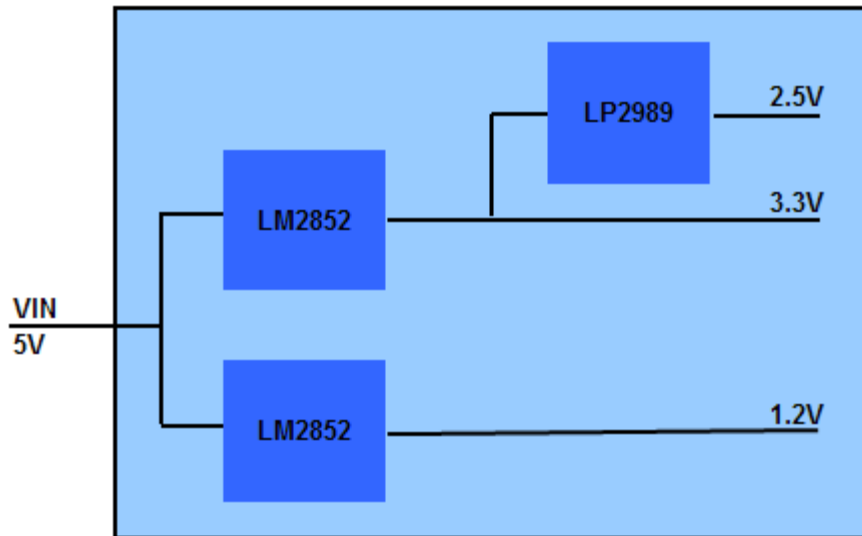

Reset Signal

Function	Pin	Signal Name
Power Good	24	RSTn

Table 2

I/O Connections

SDRAM

An ISSI 128Mbit SDRAM is used on the DB_START_4CE10 development Board. The IS42S32400A Device is a 4Mx32bit SDRAM. Table 7 shows the wiring between the FPGA and the SDRAM. The Clock of the SDRAM comes directly from the FPGA. Figure 3 shows the settings of the SOPC-Builder Component.

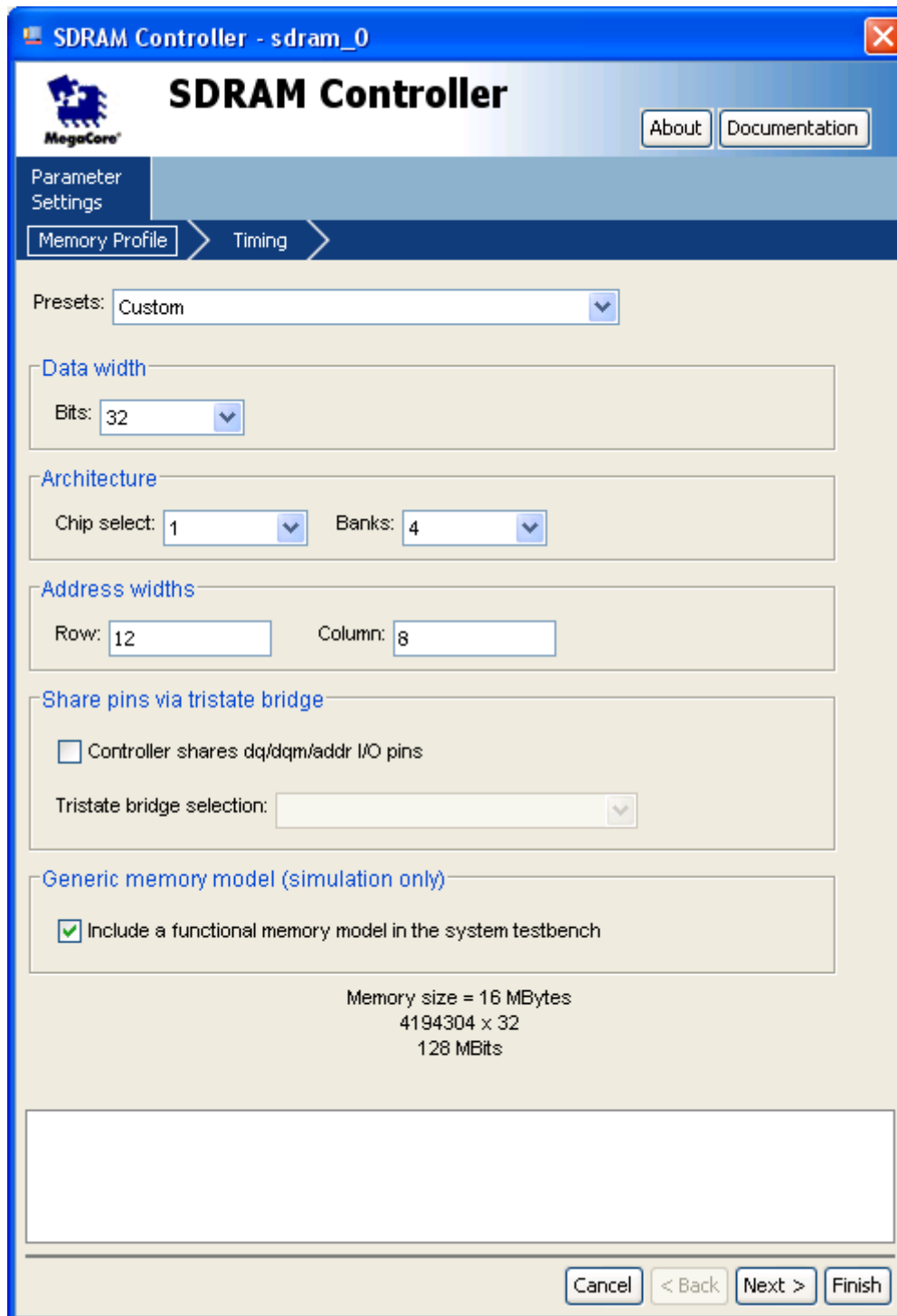

Figure 3

DB_START_4CE10 – Cyclone IV Development Board

Figure 4 shows the SDRAM Timing Settings up to 66MHz Design. For more than 66MHz set the CAS latency cycles to 3!

The clock phase for the SDRAM must be set that the sum of PLL Offset and tco for the SDRAM clock signal is about -1.2ns . The PLL Offset value can be found in the Quartus compilation report, Timing Analysis, Clock Setting Summary. The tco can be found in the tco-section.

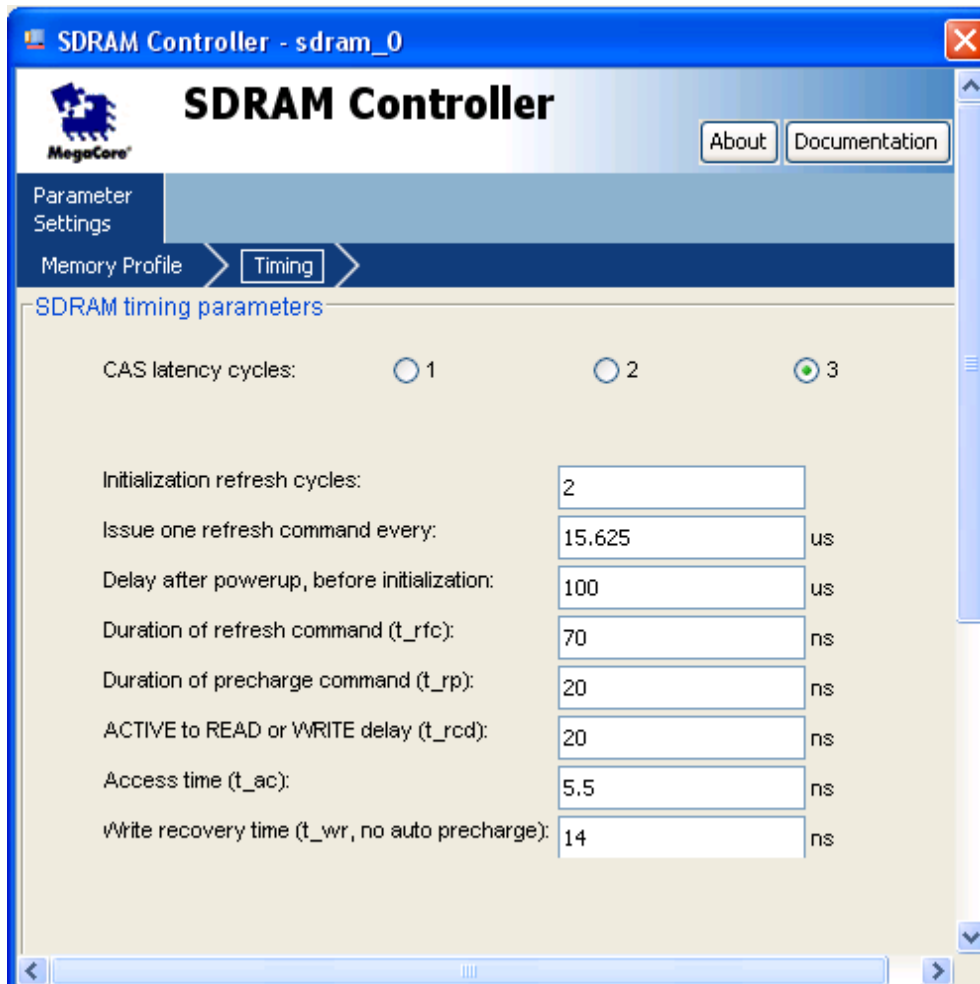

Figure 4

FPGA Connection

Function	Pin	FPGA Pin
SCLK	68	127
CKE	67	128
NCS	20	59
NRAS	19	60
NCAS	18	126
NSWE	17	125
DQM0	16	64
DQM1	71	124
DQM2	28	49
DQM3	59	142
A0	25	52

DB_START_4CE10 – Cyclone IV Development Board

Function	Pin	FPGA Pin
A1	26	51
A2	27	50
A3	60	141
A4	61	138
A5	62	137
A6	63	135
A7	64	133
A8	65	132
A9	66	129
A10	24	53
A11	21	58
BA0	22	55
BA1	23	54
DQ0	2	73
DQ1	4	72
DQ2	5	71
DQ3	7	70
DQ4	8	69
DQ5	10	68
DQ6	11	67
DQ7	13	66
DQ8	74	74
DQ9	76	75
DQ10	77	76
DQ11	79	77
DQ12	80	80
DQ13	82	84
DQ14	83	85
DQ15	85	86
DQ16	31	44
DQ17	33	43
DQ18	34	42
DQ19	36	39
DQ20	37	38
DQ21	39	34
DQ22	40	33
DQ23	42	32
DQ24	45	28
DQ25	47	30
DQ26	48	10
DQ27	50	3
DQ28	51	2
DQ29	53	1
DQ30	54	144
DQ31	56	143

Table 3

DB_START_4CE10 – Cyclone IV Development Board

Pin Header

A Pin header with 32 signals is directly connected to the FPGA. Table 4 shows the pinning and the FPGA connection for Pin Header P6.

Make sure that only 3.3V signals are connected to the Pin Headers P6.

I/O Connector P6

Function	FPGA	Pin	Pin	FPGA	Function
GND		1	2		GND
GIO0	110	3	4	106	GIO1
GIO2	105	5	6	104	GIO3
GIO4	103	7	8	101	GIO5
GIO6	100	9	10	99	GIO7
GIN0	91	11	12	90	GIN1
GIN2	89	13	14	88	GIN3
GIN4	25	15	16		
GND		17	18		GND
GIO8	87	19	20	98	GIO9
GIO10	83	21	22	11	GIO11
GIO12	136	23	24	7	GIO13
GIO14	31	25	26	121	GIO15
GIO16	46	27	28	120	GIO17
GIO18	65	29	30		GND
GND		31	31		GND

Table 4

Attention : Signals GIN3 and GIN4 are shared with the buttons!

DB_START_4CE10 – Cyclone IV Development Board

Buttons & LEDs

2 Buttons and 6 LEDs are available on the DB-START-4CE10 Development Board. The buttons are equipped with a 10K Pull-down resistor and are shared with the respective Input pins on connector P6. The LEDs are connected to 3.3V. To light the LED the FPGA must drive a Low signal. Table 5 shows the FPGA connection of the Buttons and LEDs.

FPGA Connection

Function	Device	Pin	FPGA Pin
Button0	P3	1	88
Button1	P4	1	25
LED0	D2	1	111
LED1	D3	1	112
LED2	D9	1	113
LED3	D10	1	114
LED4	D11	1	115
LED5	D12	1	119

Table 5

Bill of Material

Description	Count	SMD	Package	Reference Designator
AT93C46-DN-SH-B	1	Y	SO8	U4
BC850B	1	Y	SOT23	U13
C0603_100NA50V	33	Y	C0603	C14 C15 C57 C110 C111 C112 C117 C119 C13 C16 C19 C22 C34 C35 C36 C37 C38 C39 C40 C41 C91 C92 C93 C94 C95 C96 C173 C1 C3 C4 C5 C30 C32
C0603_10N0A50V	2	Y	C0603	C6 174
C0603_2N20A50V	2	Y	C0603	C29 C31
C0805_10UFA10V	7	Y	C0805	C2 C8 C9 C45 C46 C47 C48
C1206_1N00A2KV	1	Y	C1206	C7
C1210_100UA6V3	2	Y	C1210	C33 C43
DC10A	1	N		P12
EP4C10E22C8N	1	Y	TQ144	U1
EPCS16S18N	1	Y	SO8	U2
EPM240T100C5N	1	Y	TQ100	U5
FSM6JSMA	2	Y		P3 P4
FT245BL	1	Y		U10
IS42S32400E-6TL	1	Y	TSSOP68	U11
L0603_10NHA0A4 EPCOS B82496C3100J	2	Y	S0603BR	L3 L4
L0805_330RA2A0 Würth 742792037	1	Y	L0805	L1
LED 0603_Blau	8	Y	R0603	D1 D2 D3 D9 D10 D11 D12 D15
LM2852XMXA-1.2	1	Y	TSSOP14	U9
LM2852XMXA-3.3	1	Y	TSSOP14	U14
LP2992AIM5-2.5	1	Y	SOT23-5	U12
LWE-T_1U0A2A7 Würth 744042001	2	Y	WE-TPC-M	L7 L8
MBR0530T3	1	Y	SOD-123R	D5
R0603_100KA1%0	1	Y	R0603	R22
R0603_10K0A1%0	17	Y	R0603	R1 R2 R3 R4 R5 R9 R11 R13 R17 R18 R19 R24 R25 R28 R29 R30 R31
R0603_10RA1%0	1	Y	R0603	R139
R0603_1K00A1%0	5	Y	R0603	R6 R16 R20 R27 R33
R0603_1K50A1%0	1	Y	R0603	R12
R0603_22R0A1%0	2	Y	R0603	R7 R8
R0603_2K20A1%0	1	Y	R0603	R10
R0603_330RA1%0	7	Y	R0603	R21 R87 R89 R90 R91 R93 R94
R0603_33R0A1%0	3	Y	R0603	R34 R35 R57

DB_START_4CE10 – Cyclone IV Development Board

Description	Count	SMD	Package	Reference Designator
R0603_470RA1%0	2	Y	R0603	R14 R23
R0603_680RA1%0	1	Y	R0603	R26
SMAJ5CA	1	Y	SMA	D4
SN65220DBVT	1	Y	SO8	U3
TPS3103K33DVBR	1	Y	SOT23-5	U17
TPS21115APW	1	Y	TSSOP8	U6
TSM-116-01-L-DV-A	1	Y		P6
USB_MINI_AB	1	Y	MOLEX	P2
O 24-JO32-B-3,3-1-L	1	Y	JO32	U6

Table 6

Embedded USB Blaster

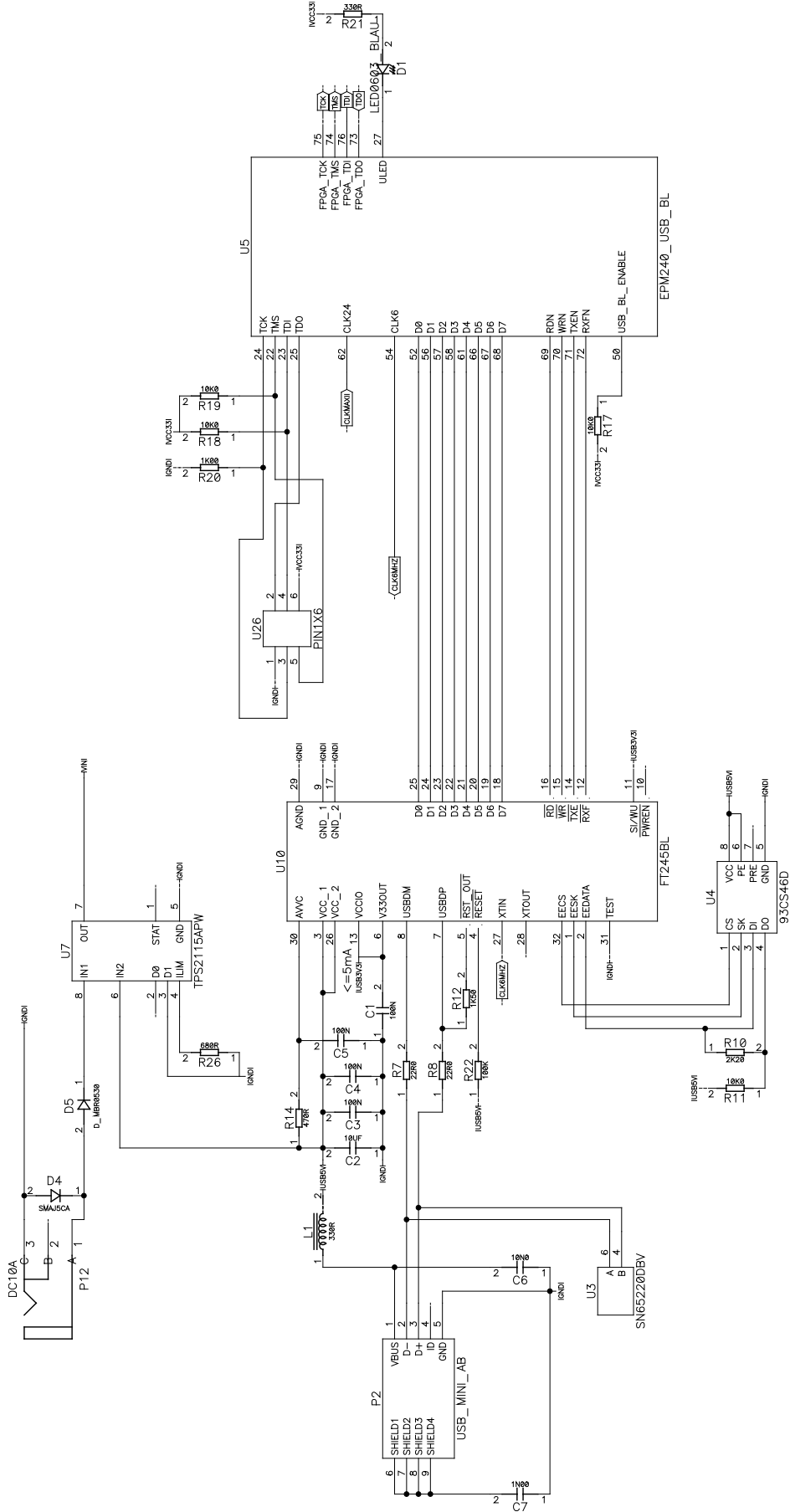

Board Top View

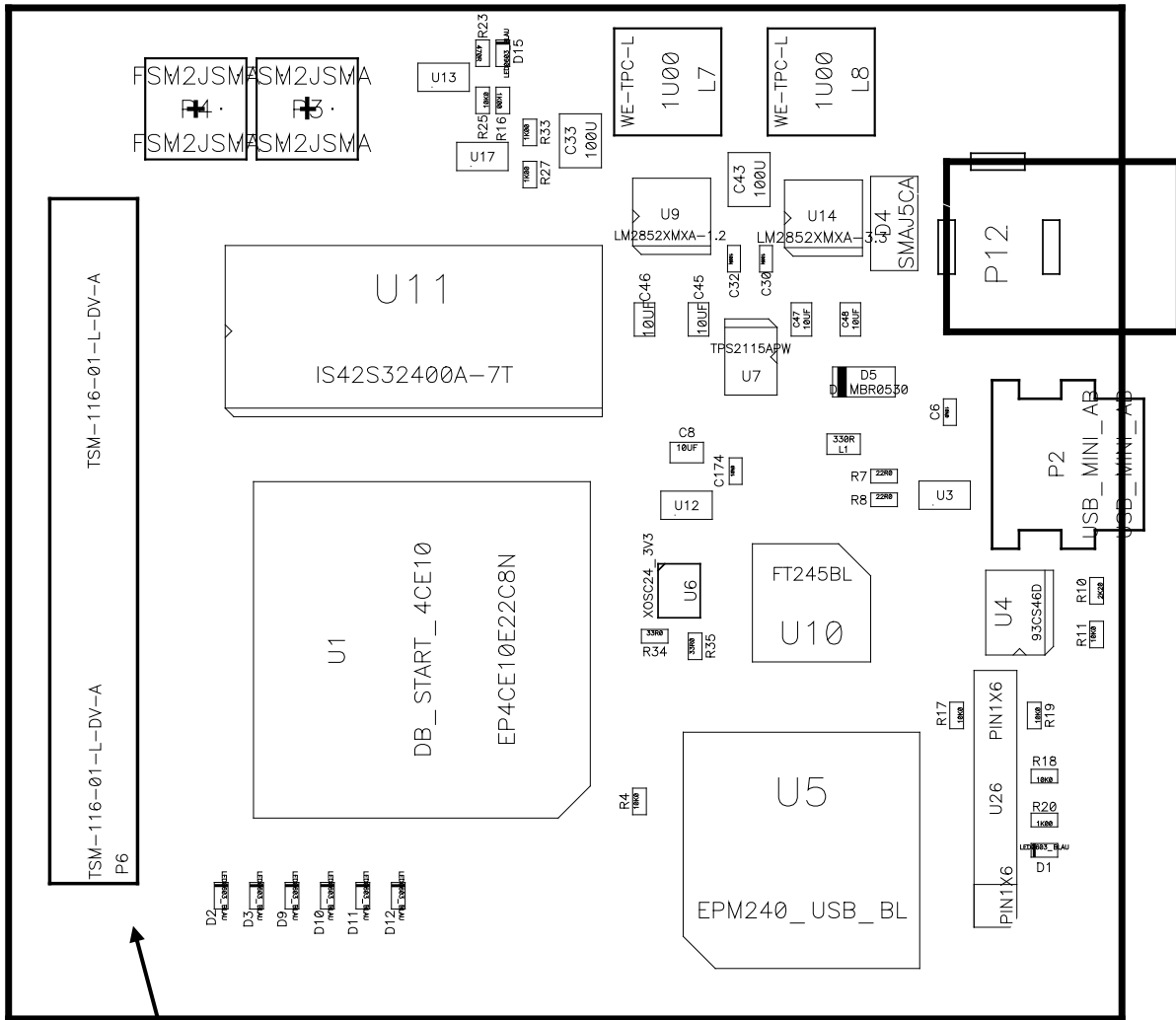

Figure 5

Pin 1

